

Tigrip® Load Hoisting Tackle Permanent load lifting magnets



TIGRIP® T-MAG

Permanent load lifting magnet

Capacity

125 - 2000 kg (Flat material),
50 - 1000 kg (Round material)

The permanent lifting magnets of the T-MAG series are ideal for the simple, fast and therefore economical transport of heavy workpieces made of ferromagnetic material. The use of high-quality neodymium material enables a large lifting force with a low dead weight.

Both flat and round materials can be picked up. The load is not influenced mechanically. After switching off, there is only a small amount of residual magnetism.

Thanks to the simple Easy Switch operation, the lifting magnet can be switched over quickly and safely with just one hand. This reliable system enables not only safe and practical, but also faster work with up to 40% time savings.

When activated, the operating lever is locked by a safety lock so that unintentional demagnetization is prevented.

Features

- The simple "EASY SWITCH" enables one-hand operation.
- Extremely robust and compact design
- Easy to maintenance and service
- Low dead weight
- Low residual magnetism after switch-off
- High temperature range up to max. 80 °C
- Made in EU
- Safety factor 3:1 according to DIN EN 13155

"Easy Switch" ALLOWS SINGLE-HANDED OPERATION



INFO

The selection of the appropriate magnet model should be made under consideration of the varying conditions of the contact surface, kind of material alloy, ambient temperature and plate thickness.

For further information, please have a look into the manual.

DIVERSE POSSIBILITIES OF APPLICATION

The areas of application of this load handling device are very diverse and range from typical workshop applications to aligning tools in machining centers to rough use in steelworks, shipyards and even offshore.



Tigrip® Load Hoisting Tackle Permanent load lifting magnets

Technical data T-MAG

Model	Art.-No.	Flat material			Round material			Test load	Weight
		Capacity ¹ max.	Material thickness min. at max. capacity	Length of material max.	Capacity ¹ max.	Diameter min. - max.	Length of material max.		
		kg	mm	mm	kg	mm	mm	kg	kg
T-MAG 125	192047639	125	25	2500	65	50 - 100	2500	375	3
T-MAG 250	192047640	250	30	3500	125	60 - 200	3500	750	10
T-MAG 500	192047641	500	40	4000	250	65 - 270	4000	1500	21
T-MAG 1000	192047642	1000	60	4500	500	100 - 300	4500	3000	40
T-MAG 2000	192047643	2000	80	5000	1000	150 - 350	5000	6000	90

¹ Measured on bright drawn material S235JR (ST 37), air gap <0,1 mm

Dimensions T-MAG

Model	T-MAG 125	T-MAG 250	T-MAG 500	T-MAG 1000	T-MAG 2000
A, mm	93	152	246	306	478
B, mm	60	100	120	146	165
C, mm	120	180	180	236	273
D, mm	125	182	185	225	265

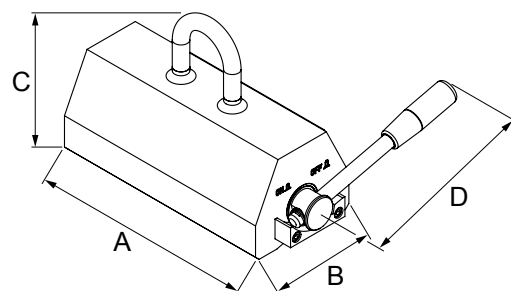

INFO

In order to achieve a maximum capacity, the contact surface should be bright and free from dirt, oil, grease, scale, corrosion, paint etc.



Tigrip® Load Hoisting Tackle Permanent load lifting magnets



TPM

Permanent load lifting magnet

Capacity

100 - 3000 kg (Flat material)

50 - 1500 kg (Round material)

TPM load lifting magnets are ideal tools for easy, quick and thus economical transport of heavy objects made of ferro-magnetic material. Typical operating areas are workshops and warehouses, loading and unloading of machines as well as construction of jigs and fixtures. Compact design of the units for a large number of applications.

The load is not affected mechanically which allows lifting of flat as well as round material. The efficient magnet body provides strong lifting capacity at low dead weight. The permanent magnets do not require electric energy and will leave only minor residual magnetism on the material after use.

The magnets are activated/deactivated easily by turning a locking lever. In activated condition the hand lever will be safely locked and thus prevent unintended demagnetising.

The selection of the appropriate magnet model should be made under consideration of the varying conditions of the contact surface, kind of material alloy and plate thickness / bar diameter (see table).

INFO

In order to achieve a maximum capacity, the contact surface should be bright and free from dirt, oil, grease, scale, corrosion, paint etc.



Tigrip® Load Hoisting Tackle Permanent load lifting magnets

Technical data TPM

Model	Art.-No.	Flat material			Round material			Test load	Weight
		Capacity ¹ max. kg	Material thickness min. at max. capacity mm	Length of material max. mm	Capacity ¹ max. kg	Diameter min. - max. mm	Length of material max. mm		
TPM 0,1	N56400001	100	14	2000	50	40 - 300	2000	300	5.3
TPM 0,3	N56400002	300	20	2500	150	60 - 300	2500	900	13.5
TPM 0,5	N56400003	500	24	3000	250	60 - 400	3000	1500	27.5
TPM 0,8	N56400004	800	34	3500	400	60 - 400	3500	2400	52.0
TPM 1,0	N56400005	1000	40	3500	500	80 - 400	3500	3000	57.0
TPM 2,0	N56400006	2000	55	3500	1000	100 - 400	3500	6000	125.0
TPM 3,0	192019927	3000	65	3500	1500	200 - 500	3500	9000	195.0

¹ Measured on bright drawn material S235JR (ST 37), air gap <0,1 mm

Dimensions TPM

Model	TPM 0,1	TPM 0,3	TPM 0,5	TPM 0,8	TPM 1,0	TPM 2,0	TPM 3,0
A, mm	122	192	232	302	332	392	497
B, mm	69	95	120	154	154	196	220
C, mm	185	225	270	320	320	420	453
D, mm	160	250	250	450	450	450	600

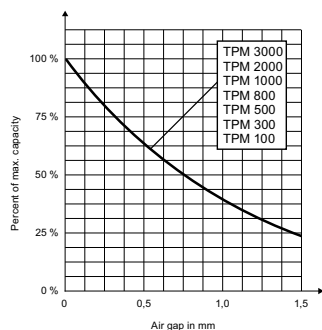

Diagram: WLL/air gap

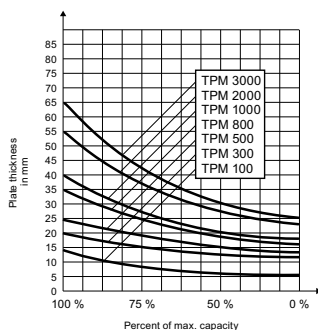
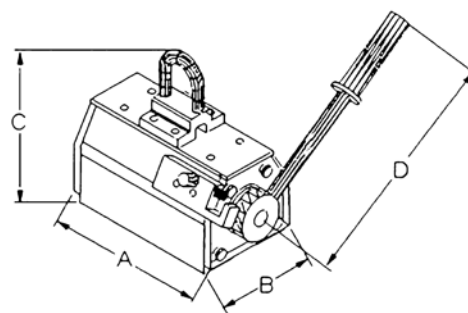
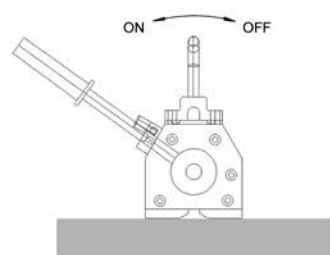

Diagram: WLL/material thickness



TPM



Correct use On/Off

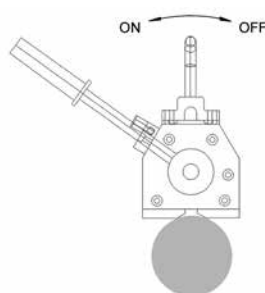

Reduction of capacity	% of capacity
Temperature ≤ 60 °C	100 %
Humidity ≤ 80 %	100 %
St 52	95 %
Alloy steel	80 %
High carbon steel	70 %
Cast iron	45 %
Nickel	10 %
Austenitic, stainless steel	0 %
Brass	0 %
Aluminium	0 %



